

5

4

3

2

1

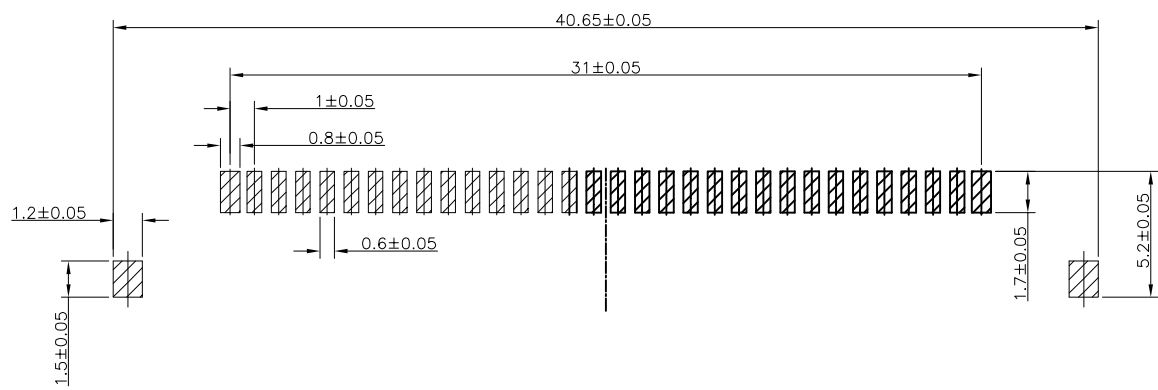
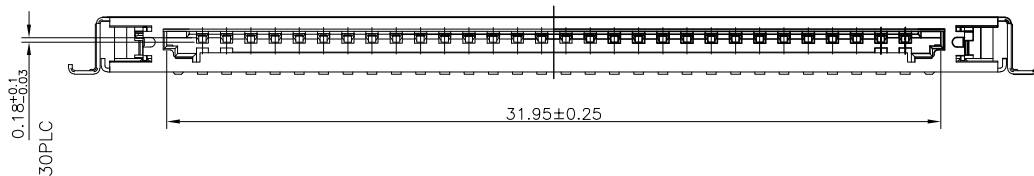
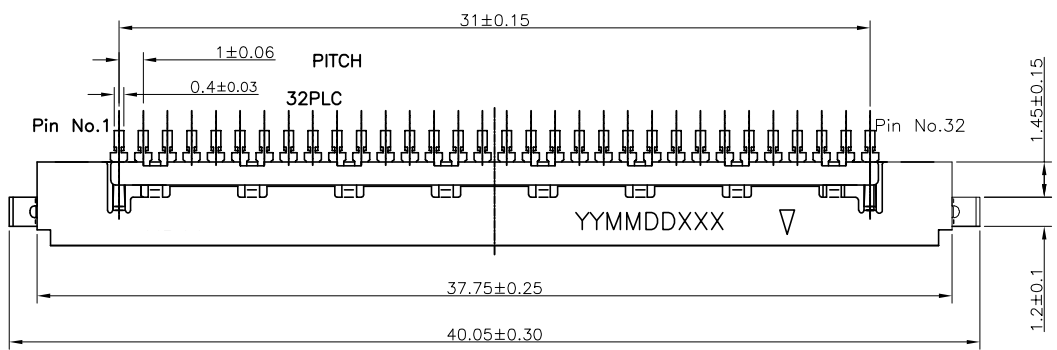

**P.C.B LAYOUT**  
SCAL 1:1

A1001 W V - 1\*NP X - X - X X - NK-HF

代码 间距

PIN数 X 本色 X 普通  
B 黑色 B 带扣  
R 红色 U 超薄  
L 蓝色 PH 组合排针  
Y 黄色 FH 组合排母  
G 绿色 H 高弯  
K 打脚K  
D 防呆型 LQ 带定位无K  
V 示意180°直针, VS 立式 R 示意90°弯针, RS 卧式 KLO 带定位打K  
RG 高弯

1 单排 2 双排

G为PIN针镀金 S为PIN针镀锡

NK为NO MARK MK为有MARK

HF 无卤 NF 普通含卤

1为PPS,2为PBT,3为LCP,4为ABS,5为PA6T,6为PA66

V 示意针座  
W 后无0默认材质为V0  
W 后带2示意V2

- NOTES:
- MATERIAL:  
HOUSING: HEIGHT TERMOPLASTIC, UL94V\_0, COLOR: Natural  
CONTACT: COPPER ALLOY, T=0.15mm  
SHELL: STAINLESS STEEL, T=0.15mm
  - FINISH:  
CONTACT: 3u" Min GOLD PLATING ON CONTACT AREA  
MATTE TIN 75u" Min OVERALL 50u" NICKEL UNDR PLATED. (LEAD FREE)  
SHELL: 50u" Min MATTE TIN OVERALL 50u" Min NICKEL UNDER PLATED. (LEAD FREE)
  - COPLANARITY BETWEEN TERMINAL AND HOLD DOWN OF SHELL SHOULD BE 0.08mm MAX.

# 东莞市平达电子科技有限公司

料号PART NO: 1001WRS-1*30PX-X				一般公差 GENERAL TOLERANCE	
品名 TITLE: SH1.0 卧贴30P				X.X ±0.30	
材料:		单位: MM	包装规格:	X.XX ±0.25	
日期版次 REVISION		日期 DATE	变更内容 DESCRIPTION	核 准 APPROVALBY	比例: 1:1
制图:		审核:	核准:	日期: 2022/7/8	ANGLE ±1°

6

5

4

3

2

1

5

4

3

2

1

F

E

D

C

B

A

F

E

D

C

B

A

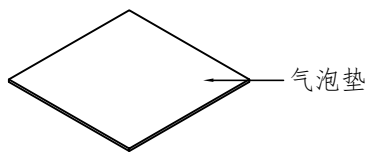

气泡垫

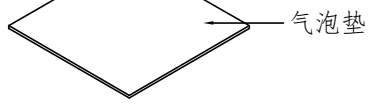
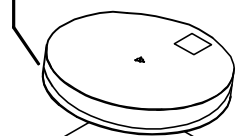
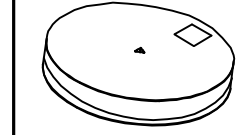
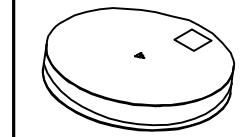
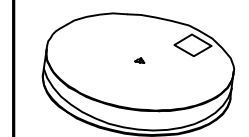
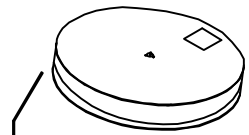

气泡垫

5卷

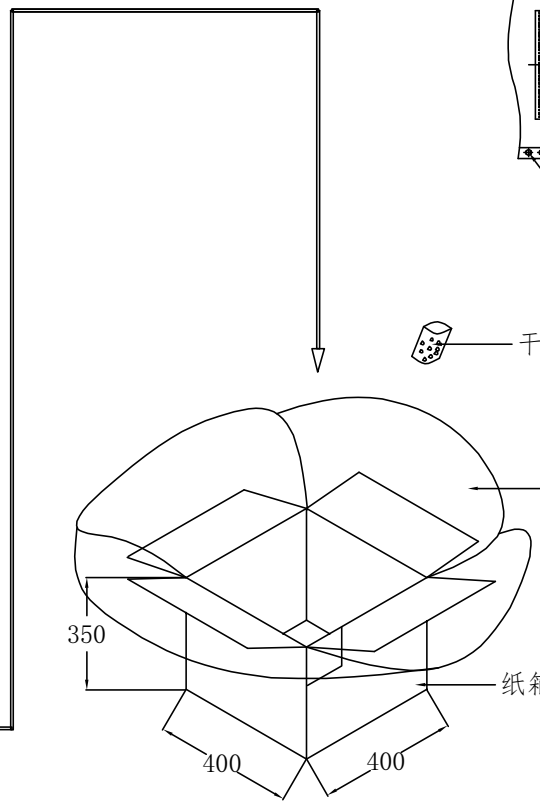
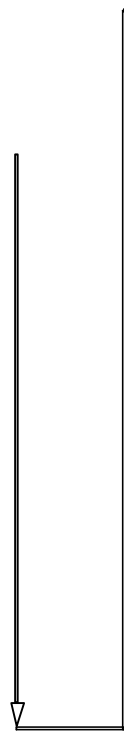

防水袋

纸箱

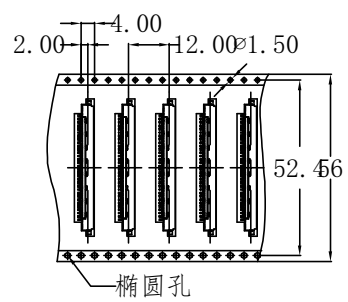

椭圆孔

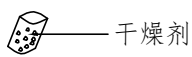

干燥剂

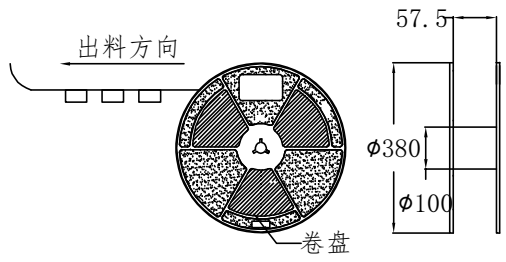

卷盘

包装说明:

1. 载带前后各空出250-300mm长度不装产品。
2. 每穴放入1PCS产品，放置方式如图示。
3. 卷带收盘完成后，在缠上一圈保护带，每卷贴1PCS标签。
4. 包装数量:2KPCS/卷，5卷/箱，10KPCS/箱。
5. 将防水袋放入纸箱并铺展开。
6. 先在纸箱底部(防水袋内)放入1PCS气泡垫，依次把5卷产品放入纸箱，放入2PCS干燥剂，再放入1PCS气泡垫，最后用胶带封箱。

# 东莞市平达电子科技有限公司

				料号PART NO: 1001WRS-1*30PX-X				一般公差 GENERAL TOLERANCE	
				品名 TITLE: SH1.0贴片30P				X.X ±0.30	
				材料:		单位: MM		包装规格:	
				比例: 1:1		角度: ±1°			
日期版次 REVISION		日期 DATE		变更内容 DESCRIPTION		核 准 APPROVALBY		制图:	
								日期: 2022/7/8	

6

5

4

3

2

1