

5

4

3

2

1

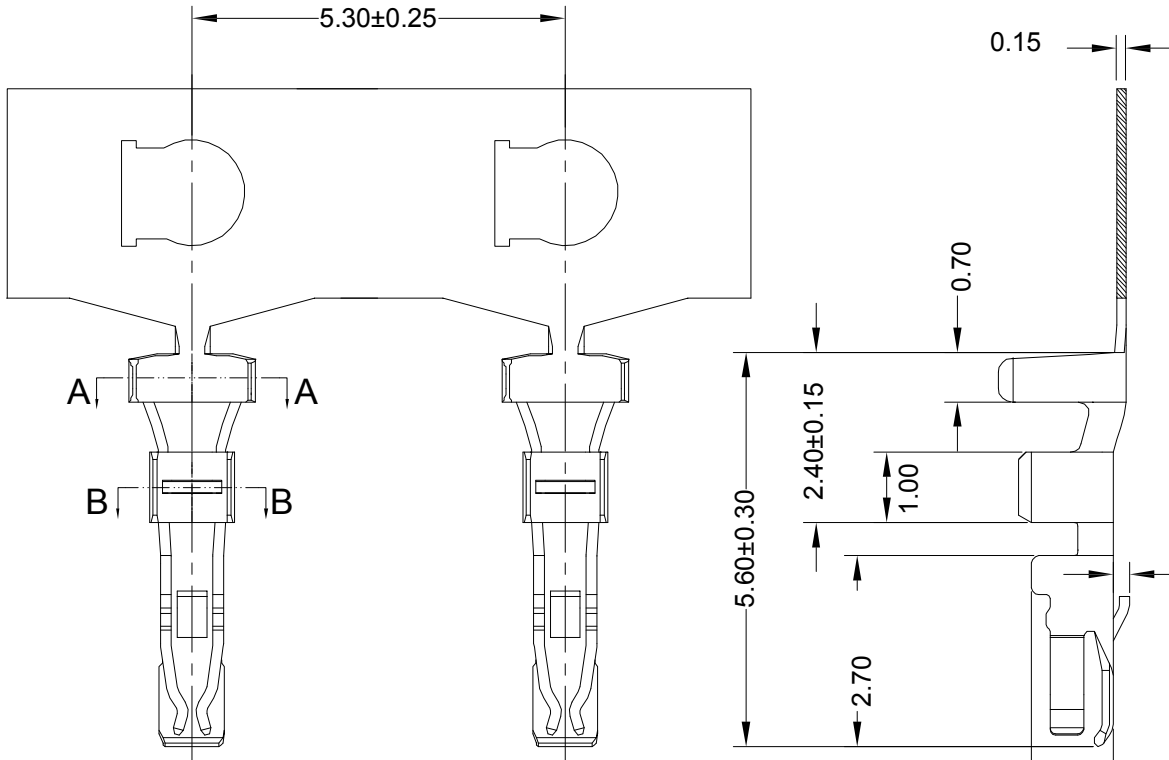

1507-T	Phosphor Bronze	AWG#24-28	1.10mm(Max)	Stamping Before Plating:30u" Ni MIN; Gold Flash	1507H
1507-T				Stamping Before Plating:30u" Ni MIN; 70u"Sn Min.	
PART NO	Material	Wire Range	Insulation	O.D.	Used In PDHousing

- Specifications :
- Voltage rating: 150V AC / DC
 - Current rating: 3A AC / DC
 - Withstanding voltage: 500V AC/minute
 - Temperature range: -25°C~+85°C
 - Insulation resistance: ≥1000MΩ
 - Contact resistance: ≤20mΩ
 - After environmental testing: ≤40mΩ

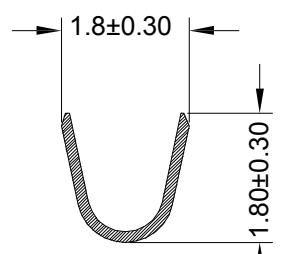

SECTION: A-A
SCALE: 1:1

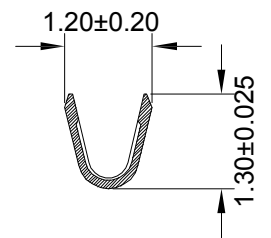

SECTION: B-B
SCALE: 1:1

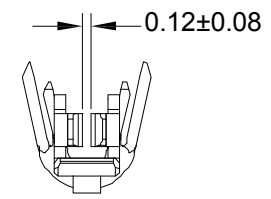

A1507 T P X - 2 X - X

代码+间距	T 示端子	P 磷铜 B 黄铜 E 合金铜	X 普通脚 H 高脚	0 素材 2 镀锡先冲后镀 3 镀锡先镀后冲 4 镀金(镀后冲) 4.2 镀金(镀先冲后镀) 5G、156 示镀金30"或15U", 16 示镀金1U"	X 公端 G 母端 C 示意90° S 示意180°
-------	-------	-----------------------	---------------	---	-------------------------------------

东莞市平达电子科技有限公司

				料号PART NO: A1507TPX-2X-G				一般公差 GENERAL TOLERANCE	
				品名 TITLE: 1507-T				X.X ±0.30	
				材料:		单位: MM		包装规格:	
				比例: 1:1		日期: 2021.12.08		ANGLE ±1°	
日期版次 REVISION	日期 DATE	变更内容 DESCRIPTION	核 准 APPROVALBY	制图:	审核:	核准:			

6

5

4

3

2

1

PD